

MOD : E22/GPLP3-HP

Production code : 393348



Modular Cooking Range Line ECO 90 Electric Grill Top HP 1200mm

ITEM # _____

MODEL # _____

NAME # _____

SIS # _____

AIA # _____

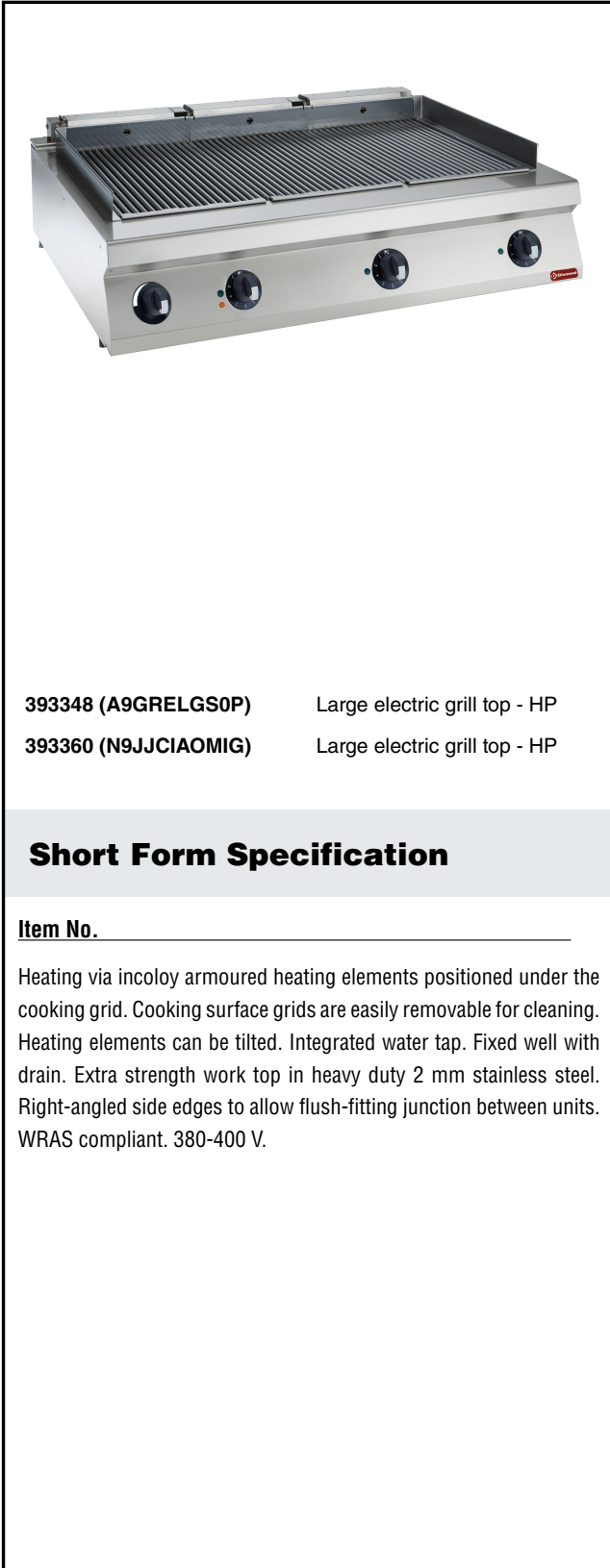

- 393348 (A9GRELGS0P) Large electric grill top - HP
- 393360 (N9JJCIAOMIG) Large electric grill top - HP

Short Form Specification

Item No. _____

Heating via incoloy armoured heating elements positioned under the cooking grid. Cooking surface grids are easily removable for cleaning. Heating elements can be tilted. Integrated water tap. Fixed well with drain. Extra strength work top in heavy duty 2 mm stainless steel. Right-angled side edges to allow flush-fitting junction between units. WRAS compliant. 380-400 V.

Main Features

- Incoloy armoured heating elements positioned under the cooking grid.
- Each bank of elements has an independent power regulation through a control knob.
- Fixed well with drain to collect residual cooking juices and grease.
- Water filling tap with knob control.
- Led warning indicator to give an alarm when well is empty.
- Removable stainless steel deflectors to recuperate heat and reduce cooking time.
- Stainless steel splash guards on sides of cooking surface. Splash guards can be easily removed for cleaning.
- Top configuration allows installation on ambient base or refrigerated/freezer base.
- Removable 2mm thick steel U-shaped grids for fast heating of cooking surface.
- Large drain protected by overflow and filter.
- Water must be added to well before operation.
- Suitable for countertop installation.

Construction

- Unit is 900mm deep to give a larger working surface area.

Included Accessories

- 1 of SCRAPER FOR HP ELECTRIC GRILL PNC 206436

Optional Accessories

- JUNCTION SEALING KIT PNC 206086
- SUPPORT FOR "BRIDGE" SYSTEM 1200 MM PNC 206139
- SUPPORT FOR "BRIDGE" SYSTEM 1400 MM PNC 206140
- SUPPORT FOR "BRIDGE" SYSTEM 1600 MM PNC 206141
- SIDE HANDRAIL-RIGHT/LEFT HAND-900 LINE PNC 206165
- FRONTAL HANDRAIL 1200 MM PNC 206191
- FRONTAL HANDRAIL 1600 MM PNC 206192
- 2 SIDE COVERING PANELS H=250-D=900-Z/OEM PNC 206321
- SCRAPER FOR HP ELECTRIC GRILL PNC 206436
- DRAIN EXTENTION FOR HP ELECTRIC GRILL PNC 206437

APPROVAL: _____



Modular Cooking Range Line ECO 90 Electric Grill Top HP 1200mm

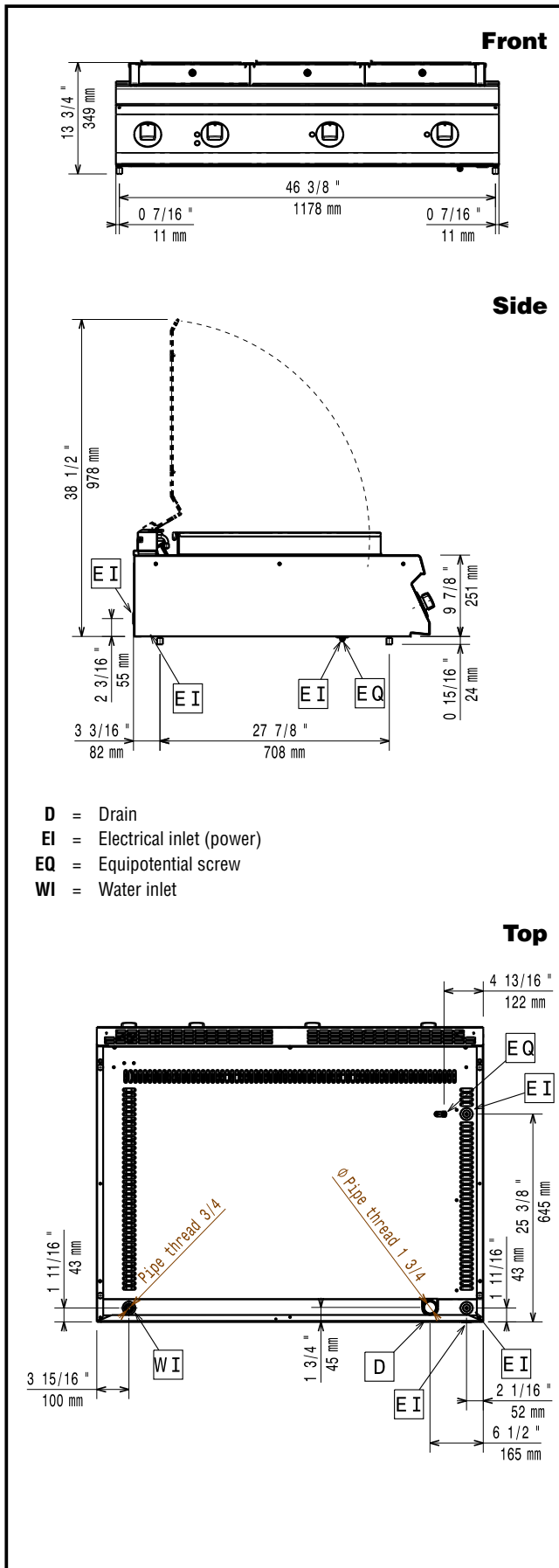

- D = Drain
- EI = Electrical inlet (power)
- EQ = Equipotential screw
- WI = Water inlet

Electric

Supply voltage:	
393348 (A9GRELGSOP)	380-400 V/3N ph/50/60 Hz
393360 (N9JJCIAOMIG)	230 V/3N ph/50/60 Hz
Electrical power max.:	
	17.4 kW
Predisposed for:	
393348 (A9GRELGSOP)	380-400V 3N~ 50/60Hz 16,2-17.4kW

Key Information:

Cooking surface width:	1065 mm
Cooking surface depth:	598 mm
External dimensions, Width:	1200 mm
External dimensions, Depth:	900 mm
External dimensions, Height:	250 mm
Net weight:	143 kg
Shipping weight:	160 kg
Shipping height:	400 mm
Shipping width:	1320 mm
Shipping depth:	960 mm
Shipping volume:	0.51 m ³

If appliance is set up either next to or against temperature sensitive furniture or similar, a safety gap of approximately 150 mm should be maintained or some form of heat insulation fitted.

Certification group: HEG9E3

Modular Cooking Range Line
ECO 90 Electric Grill Top HP 1200mm

The company reserves the right to make modifications to the products without prior notice. All information correct at time of printing.

