

02/2021

# **Mod: CF-180T/S**

**Production code: POLAR 2-85\_**



**CF-180T/S**



\*

**DESCRIPTION**

The robust, stainless steel Polar 2-85 vacuum packaging machine is standard equipped with a Busch vacuum pump. This double chamber complies with CE standards.

**FEATURES**

- Standard with 2 seal bars (front-back): 2 x 840 mm
- Standard double seal (two wires). Optional without extra costs: Cut-off or Wide seal (10 mm)
- Silicone holders easily removable for cleaning and maintenance purposes
- Pump capacity: 300 m<sup>3</sup>/h Busch vacuum pump
- Pump maintenance and cleaning program
- Machine cycle: 10-30 sec
- Soft Air to protect the product and vacuum bag
- Standard Digital control with 10 program memory and Time control
- Flat work plate
- Comes with insert plates for a faster cycle and product adjustment
- Stainless steel exterior
- IP-65 classification

**OPTIONS**

- 1-2 Cut-off/Bi-active seal
- Sensor control, Advanced Control System (ACS), Liquid control
- Automatic lid
- High lid 300 mm, with seal bars 2 x 770 mm
- Gas flush (incl. pressed air connection)
- Preparation for external pump
- Heating element for vacuum valve

**ACCESSORIES**

- Zebra ZD410 thermal label printer (only in combination with ACS)
- Inclined insert plate
- Service kit for standard maintenance



Diamond Europe s.a./n.v.

92 Chaussée de Vilvorde  
92 Vilvoordsesteenweg  
1120 Brussels  
Belgium

info@diamond-eu.com  
Phone: +32 2 420 26 26  
Fax: +32 2 420 67 66  
www.diamond-europe.com

# CF-180T/S- SPECS

## DIMENSIONS

In mm

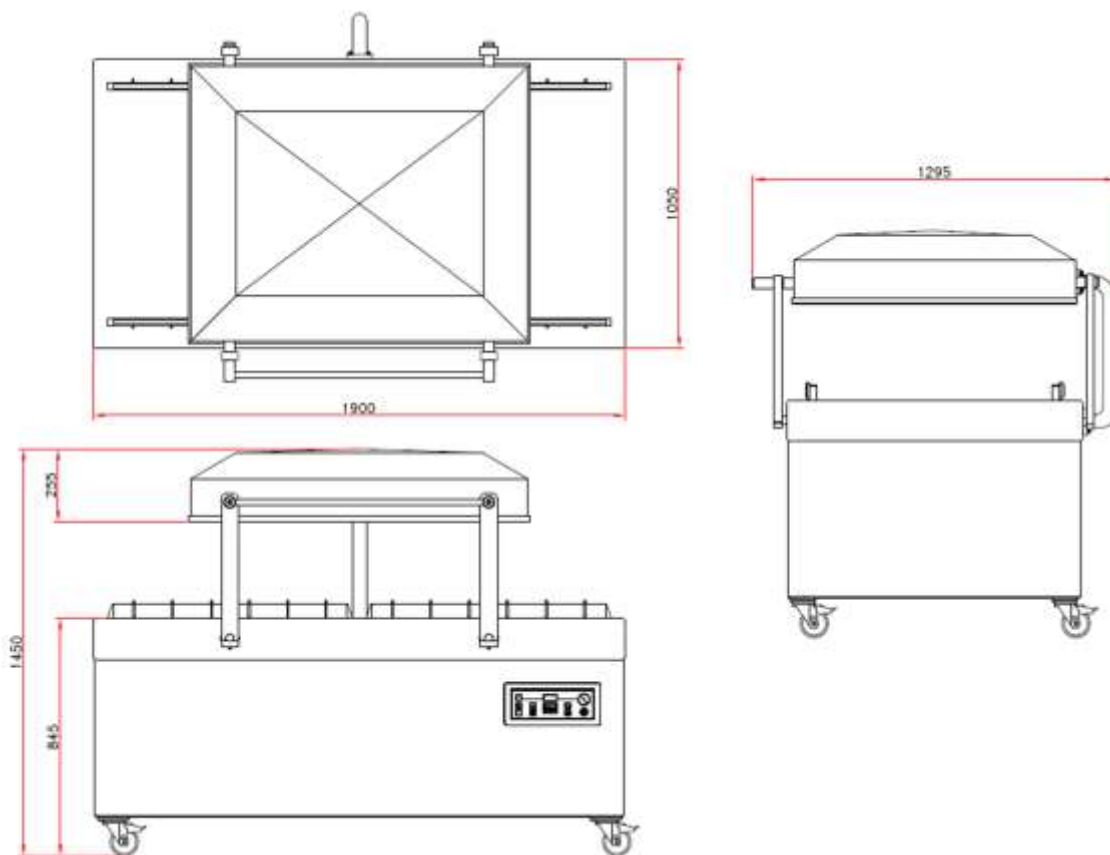

| Model      | Dimensions (mm)                  |                    | Voltage* (Hz) | Pump capacity (m <sup>3</sup> /h) | Power (kW) | Weight (kg) |
|------------|----------------------------------|--------------------|---------------|-----------------------------------|------------|-------------|
|            | Chamber (usable space) L x W x H | Machine L x W x H  |               |                                   |            |             |
| Polar 2-85 | 830 x 840 x 255                  | 1295 x 1900 x 1450 | 400V-3-50     | 300                               | 7,0 - 9,0  | 685         |

\* Other voltages available



Diamond Europe s.a./n.v.

92 Chaussée de Vilvorde  
92 Vilvoordsesteenweg  
1120 Brussels  
Belgium

info@diamond-eu.com  
Phone: +32 2 420 26 26  
Fax: +32 2 420 67 66  
www.diamond-europe.com