

09/2016

Mod: IMP/LX

Production code: IMP/ZEBRA



Diamond
catering equipment

User manual

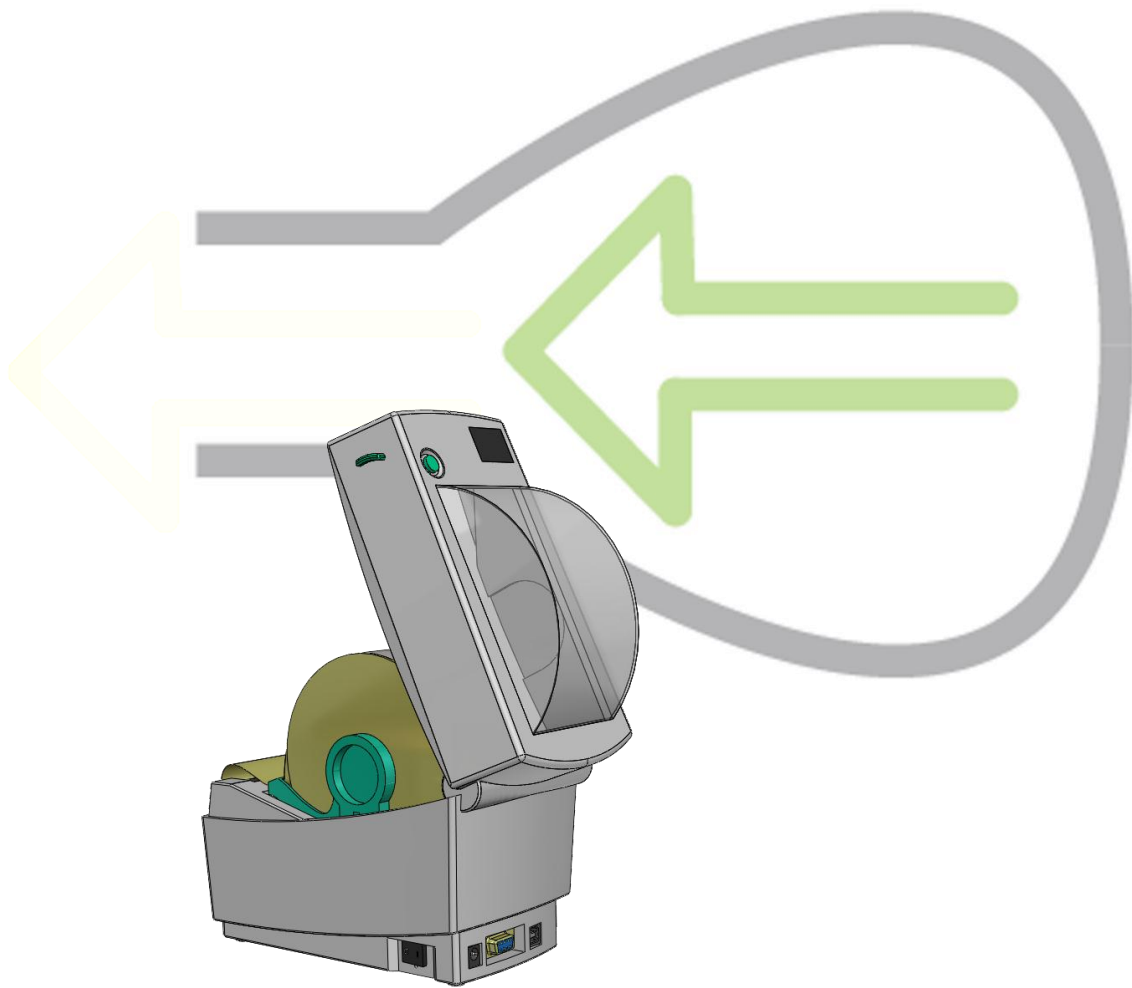

IMP/Lynx 42

CE

Connecting and operating the label printer



- Turn off the vacuum machine and connect the printer via the USB cable to the machine. Connect the power cable of the printer. Turn the vacuum machine and the printer on.

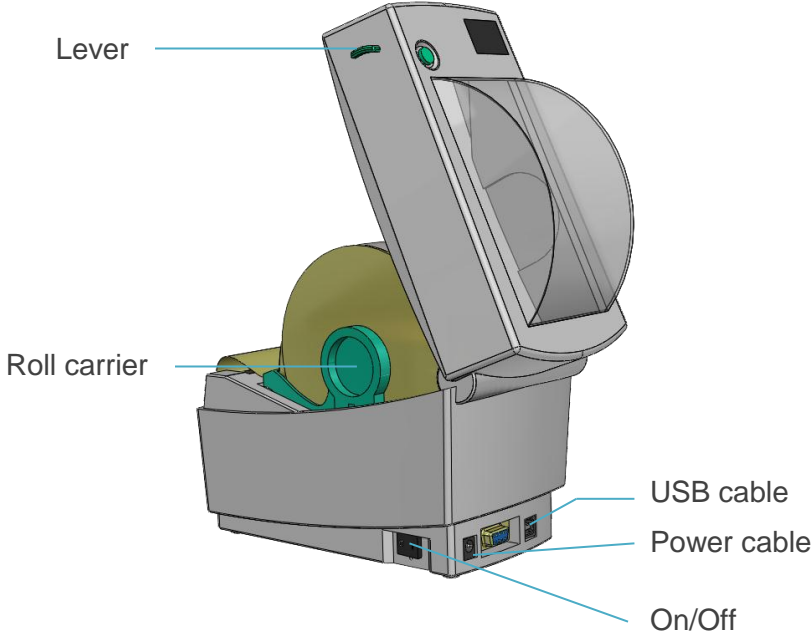

-
- To place a roll of labels in the machine. Pull the green levers on the side forwards and open the lid. Remove at least two labels from the backing foil. Push the roll carriers outside and place the roll between them. Then pull the dispenser down to create an opening. Now lead the label foil as shown in the picture.

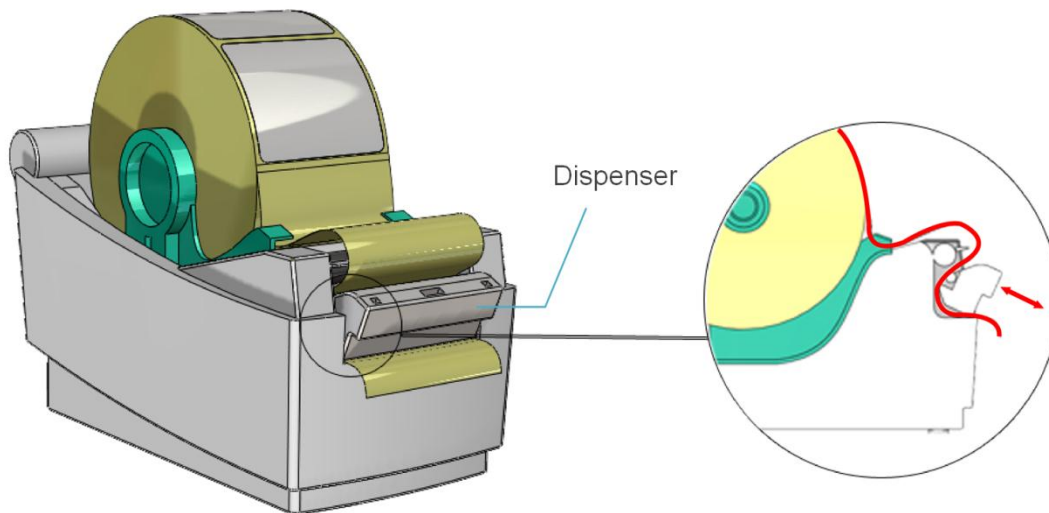

- Close the dispenser if the label foil is correctly placed.
- Now close the lid and push the green button on top once. The printer now automatically goes to the next label.
- When using a different length of label, you have to recalibrate the printer. The above steps are equal. Just hold the green button till the light under the button blinks twice. Now the sensors register the length of the new label.
- For activating the printer and changing the setting, check the chapter 'Settings'.

It is not possible to change the type of font or font size of the printed text on the label. Using a label with a different size as the supplied label, might result in a situation where the printed text will be unreadable.

The setting of the printer is based upon a label roll that has separate labels. The free space between two labels is used to determine the length of the label. Using a printer roll without these free spaces will not work before the printer settings have been changed. Please review the Printer manual.

Connecting and operating external vacuum

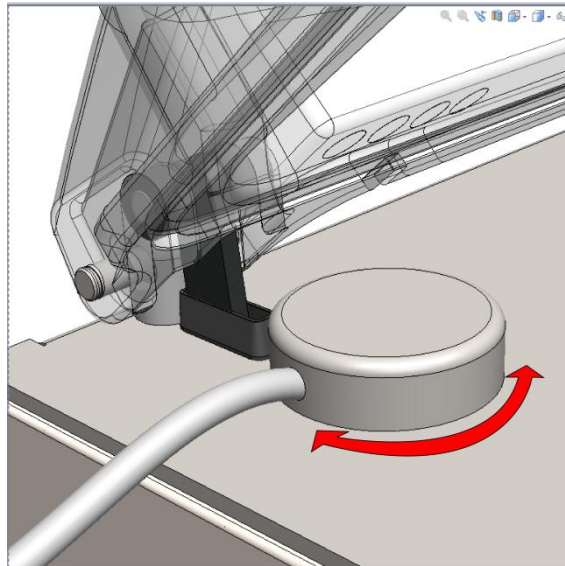

- Connect the external vacuum hose connector to the vacuum/ventilation nozzle of the machine as shown.
- Connect the other side of the external vacuum hose to the container that needs to be vacuumed. Make sure this container is capable of resisting and holding a vacuum.
- Use the control panel to select the external vacuum program ('up' ▲ or 'down' ▼)
- Press 'Enter' to start and 'Stop' to end the vacuum process.

Import / Export Menu

Exporting Data

The settings, service data, programs and labels can be exported through the USB connector. The files will be written on a USB-key in .txt format and can be read with a standard Windows PC. Only an authorization as 'Owner' or 'Distributor' allows access to this possibility.

Importing Data

Via the USB port, programs and labels can be imported from a USB-key. The data to be imported can be created using the Lynx software programming tool. Please contact your supplier for this software.

Creating programs/labels with the Lynx software programming tool

Installing the Lynx software programming tool

- Create a folder on the C-drive of your PC and name it "SoftwareLX".
- Save the zipped software package "SoftwareLX" on C:\SoftwareLX.
- Go back to the folder C:\SoftwareLX ,unzip the software package and save it in C:\SoftwareLX.

Creating a program or label

- Open the HTML document "SoftwareLX" on C:\SoftwareLX. If internet explorer shows a warning bar, click the button to allow the blocked ActiveX contents.
- Select a program or label and click the "go" -button.
- Fill out all the data you wish to use.
- Click the "save"- button to save the program or label.

Vacuum Packaging Machine Configuration Wizard

This software allows you to set preset the values of the programs and labels of the vacuum pack machine.
Please make sure that you are using Internet Explorer 8 on a Windows XP system or higher.

Select a program or label you want to change

Program:
 Label:

Label 1

Product name:	Max 22 characters	<input type="text"/>	
Gas name:	Max 20 characters	<input type="text"/>	
Print gas name:	On / Off	<input checked="" type="radio"/> On <input type="radio"/> Off	
Store temperature:	in °C	<input type="text"/> °C	
Days expiry:	in days	<input type="text"/> days	
Print expiry date:	On / Off	<input checked="" type="radio"/> On <input type="radio"/> Off	
Print result vacuum:	On / Off	<input checked="" type="radio"/> On <input type="radio"/> Off	
Print producer name:	On / Off	<input checked="" type="radio"/> On <input type="radio"/> Off	

Importing the created data

- Use an empty USB-stick and copy the .txt files (label... and prog..) of C:/SoftwareLX on the USB Stick.
- Put the USB- key into the port on the machine.
- In the “Menu”, select “Import/Export data” and go to “Import data”. When you confirm, the existing programs and labels will be overwritten by the data that have been programmed on the PC.

Note: Never change the .txt-files by opening them in notepad or any other program. This will result in corrupt files.

Note: Do not place the program and label files in a separate folder on the USB-stick.

Note: The machine will show an error message after the last imported program / label file.

This message is not important, your files are saved.