

04/2015

Mod: EMM/150I

Production code: P406 30160 (PTF IE150/N - PTF IE150/A)



Diamond
catering equipment

ROUND BOILING PANS

PTF
Model

Cylindrical cooking pot with cylindrical container designed to be positioned in passageways or in tight spaces where sharp edges or corners may create problems, making it possible to work comfortably from different angles.

TECHNICAL FEATURES

Cooking tank

- Cooking tank with bottom in AISI 316 polished stainless steel thickness from 2mm to 4mm and walls in AISI 304 stainless steel

Jacket (indirect heated version)

- Jacket with bottom and walls in AISI 304 stainless steel

Lid

- Normal version: balanced lid in AISI 304 stainless steel with heat resistant handle
- Autoclave version: balanced lid in AISI 304 stainless steel with heat resistant handle, alimentary silicon gasket, hermetic sealing clamps and safety valve at 0,05 Bar

Support frame and panels

- Stainless steel frame
- Thermal insulation assured by high density rock fibre
- Panels in AISI 304 stainless steel, fine satin finish

Heating system

Direct Gas versions

- Heating by means of AISI 304 stainless steel high efficiency tube burners
- Ignition by means of manual piezo-electric lighter and pilot flame
- Valve-controlled safety tap with thermocouple
- Venting grid
- Set of jets for different types of gas

Indirect Gas versions - with Jacket

- Heating by means of AISI 304 stainless steel high efficiency tube burners
- Ignition by means of manual piezo-electric lighter and pilot flame
- Valve-controlled safety tap with thermocouple
- Safety thermostat with burners block to overheating or lack of water
- Venting filter
- Set of jets for different types of gas
- Jacket water level control taps max/min with option of automatic filling
- Jacket pressure control by means of weight-loaded safety relief valve calibrated at 0,5 bar, vacuum valve and pressure gauge



Indirect Electric versions - with Jacket

- Heating by means of INCOLOY heating elements with adjustable power regulator
- Safety thermostat to prevent overheating and keeps the equipment from operating without water
- Jacket water level control taps max/min with option of automatic filling
- Jacket pressure control by working pressure switch and weight-loaded safety relief valve calibrated at 0,5 bar, vacuum valve and pressure gauge
- Standard power supply 3N - 400V - 50Hz

Indirect Steam versions - with Jacket

- Heating by means of steam (from user's plant line) with a throttle valve allowing a gradual steam inlet
- Jacket pressure control by means of weight-loaded safety relief valve calibrated at 0,5 bar, vacuum valve and pressure gauge

PTF	V/N	IE/N	GD/N	IG/N	V/A	IE/A	GD/A	IG/A
Jacket safety valve	•	•	-	•	•	•	-	•
Water tap	•	•	•	•	•	•	•	•
Tank drain tap	•	•	•	•	•	•	•	•
Tank drain grid	•	•	•	•	•	•	•	•
Venting grid	-	-	•	•	-	-	•	•
Valve-controlled safety tap with thermocouple	-	-	•	•	-	-	•	•
Tank safety valve	-	-	-	-	•	•	•	•
Lid with closing clamp and gasket	-	-	-	-	•	•	•	•
Safety thermostat	-	•	-	•	-	•	-	•
Pressure switch	-	•	-	*	-	•	-	*
Automatic jacket water load + water solenoid valve + probe	-	*	-	*	-	*	-	*
Automatic temperature control	*	*	*	*	*	*	*	*
Timer with buzzer	*	*	*	*	*	*	*	*
Colander pasta basket	*	*	*	*	*	*	*	*
Mixer fixed at lid	*	*	*	*	*	*	*	*
Separated mixer on tank	*	*	-	-	*	*	-	-
Separate mixer on trolley	*	*	*	*	*	*	*	*

• standard

* optional

- no

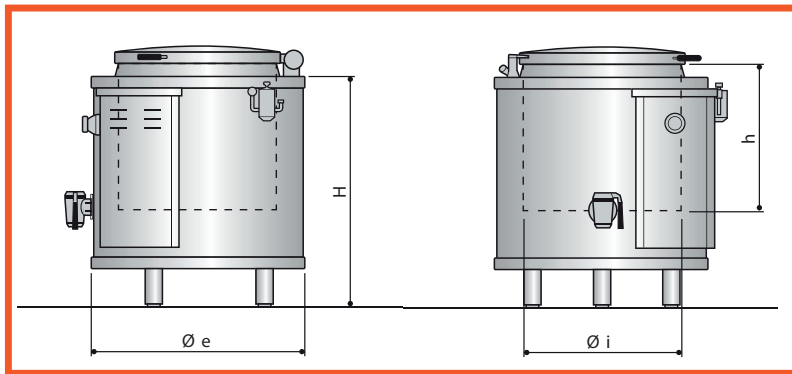

MODEL	Capacity liter	Pan Dimensions Ø e x H mm	Tank Dimensions Ø i x h mm	Power (kW)		Consumption			
				Gas	Electric	L. P. G. kg/h	Nat. Gas H m ³ /h	Nat. Gas L m ³ /h	Steam kg/h
PTF V100/N - PTF V100/A	100	Ø850x900	Ø600x420	-	-	-	-	-	60
PTF V150/N - PTF V150/A	150	Ø850x900	Ø600x540	-	-	-	-	-	65
PTF V200/N - PTF V200/A	200	Ø1000x900	Ø760x500	-	-	-	-	-	85
PTF V300/N - PTF V300/A	300	Ø1200x900	Ø960x500	-	-	-	-	-	100
PTF V500/N - PTF V500/A	500	Ø1300x100	Ø1060x600	-	-	-	-	-	115
PTF IE100/N - PTF IE100/A	100	Ø850x900	Ø600x420	-	12	-	-	-	-
PTF IE150/N - PTF IE150/A	150	Ø850x900	Ø600x540	-	16	-	-	-	-
PTF IE200/N - PTF IE200/A	200	Ø1000x900	Ø760x500	-	24	-	-	-	-
PTF IE300/N - PTF IE300/A	300	Ø1200x900	Ø960x500	-	36	-	-	-	-
PTF IE500/N - PTF IE500/A	500	Ø1300x100	Ø1060x600	-	48	-	-	-	-
PTF GD100/N - PTF GD100/A	100	Ø850x900	Ø600x420	24	-	1,86	2,48	2,46	-
PTF GD150/N - PTF GD150/A	150	Ø850x900	Ø600x540	24	-	1,86	2,48	2,46	-
PTF GD200/N - PTF GD200/A	200	Ø1000x900	Ø760x500	39	-	2,42	3,25	3,78	-
PTF GD300/N - PTF GD300/A	300	Ø1200x900	Ø960x500	39	-	2,42	3,25	3,78	-
PTF GD500/N - PTF GD500/A	500	Ø1300x100	Ø1060x600	55	-	4,62	6,21	7,21	-
PTF IG100/N - PTF IG100/A	100	Ø850x900	Ø600x420	24	-	1,74	2,74	2,3	-
PTF IG150/N - PTF IG150/A	150	Ø850x900	Ø600x540	24	-	1,74	2,74	2,46	-
PTF IG200/N - PTF IG200/A	200	Ø1000x900	Ø760x500	39	-	2,42	3,25	3,78	-
PTF IG300/N - PTF IG300/A	300	Ø1200x900	Ø960x500	48	-	3,47	4,66	5,41	-
PTF IG500/N - PTF IG500/A	500	Ø1300x100	Ø1060x600	55	-	4,62	6,21	7,21	-

V: steam

IE: indirect el.

GD: direct gas

IG: indirect gas

A: autoclave

N: normal