

## Oriental Cooking - Wok Range

### Gas - Wok table top

#### NGWT 7-55 SN



Due to continuous technical development, the image shown may not represent the latest design of the unit.

#### DESCRIPTION

Table-top gas wok with two burners, each with a power rate of 11.5/13 kW. Compact design with a depth of 600 mm. Due to the versatile usage as a wok unit, open burner or pot cooker, it is suitable for various methods of Oriental and Western cooking.

This wok is the perfect choice for catering-, street-food-, food-truck businesses and small kitchens.

Made of stainless steel AISI 304 with 1.2 mm strong top panel, burner with a cast iron pot holder and a stainless steel wok ring. Equipped with a drawer below the burner to collect grease, food debris and spillages for easy cleaning and enhanced hygienic.

#### OTHER AVAILABLE MODELS

- NGWT 3-55 SN
- NGTL 6-65 SO

#### MAIN FEATURES

- Two atmospheric burners with a power rate of 11.5/13 kW (LPG/LNG) each.
- Cast iron potholder.
- Manual ignition.
- Equipped with pilot burners, safety thermo-couples, gas valves and and gas control knobs.
- Grease collection drawer below each burner.
- CE certified unit.

#### CONSTRUCTION

- Unified body construction.
- Stainless steel top panel (1.2 mm), AISI 304 with orbital surface pattern.
- Front, back and side panels made of stainless steel AISI 430 with hairline surface pattern (1.2 mm).
- Height adjustable levelling legs.
- Type of installation: table-top.
- Frame, top and panels, all made of high-grade stainless steel.

#### INCLUDED ACCESSORIES

- Stainless steel wok ring Ø 290 mm (2 pcs).

#### OPTIONAL ACCESSORIES

- N/A

**FRONT**

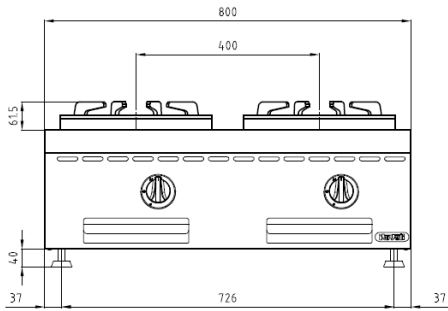

**TOP**

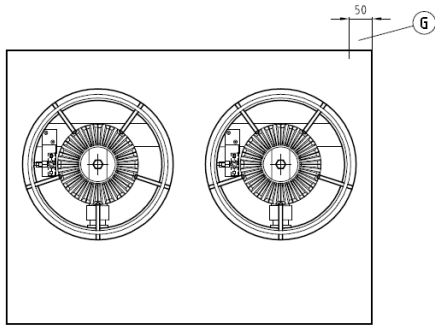

**SIDE**

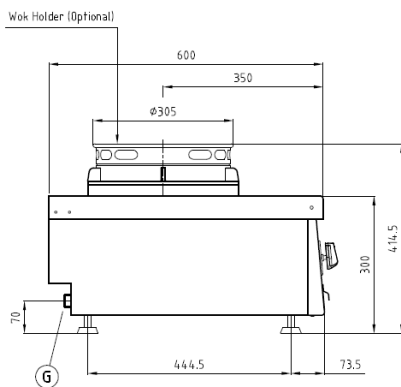

\*Overall dimension in mm

**TECHNICAL DATA**

**External Dimensions**

Width : 800 mm  
 Depth : 600 mm  
 Height : 300/361.5 mm

**Cooking Surface**

Wok burners : 2 x Ø 280 mm  
 Soup burners : N/A

**Gas Power Rating**

Heat input total : LPG 23 kW, LNG 26 kW  
 No. of burners : 2  
 Control type : High-low power control  
 Gas type options: LPG G30, G31  
 LNG G20, G25

**Connections**

Gas : DN 20 (3/4")  
 Water : N/A  
 Drain : N/A

**Heat & Steam Emissions**

Direct heat emission : LPG 5.75 kW , LNG 6.50 kW  
 Latent heat emission : LPG 3.45 kW , LNG 3.90 kW  
 Steam emission : LPG 6.10 kg/h , LNG 6.89 kg/h

**PACKAGING DATA**

Width : 830 mm  
 Depth : 630 mm  
 Height : 485 mm  
 Volume : 0.25 m<sup>3</sup>

**WEIGHT**

Net Weight : 47 kg  
 Gross Weight : 58 kg