

08/2018

# Mod: GA-80P/S

Production code: JUMBO PLUS



**Diamond**  
catering equipment

**GA-80P/S**

**DESCRIPTION**

The robust, stainless steel Jumbo Plus vacuum packaging machine is standard equipped with a Busch vacuum pump and Time control with a 1 program memory. This table-top model complies with CE standards.

**FEATURES**

- Standard with 1 seal bar (front): 280 mm
- Standard double seal (two wires). Optional without extra costs: Cut-off seal
- Seal bars easily removable for cleaning and maintenance purposes
- Pump capacity: 8 m<sup>3</sup>/h Busch vacuum pump
- Pump maintenance and cleaning program
- Machine cycle: 15-35 sec
- Standard Time control with a 1 program memory
- Deep drawn stainless steel vacuum chamber
- Stainless steel exterior and transparent lid
- Comes with insert plate for a faster cycle and product adjustment

**OPTIONS**

- High lid

**ACCESSORIES**

- Inclined insert plate (for packing liquids)
- Food container adaptor
- Service kit for standard maintenance
- Trolley with shelves

# GA-80P/S- SPECS

# VACUUM PACKAGING MACHINE JUMBO PLUS - SPEC SHEET

## DIMENSIONS

In mm

OUTER DIMENSIONS  
Jumbo Plus

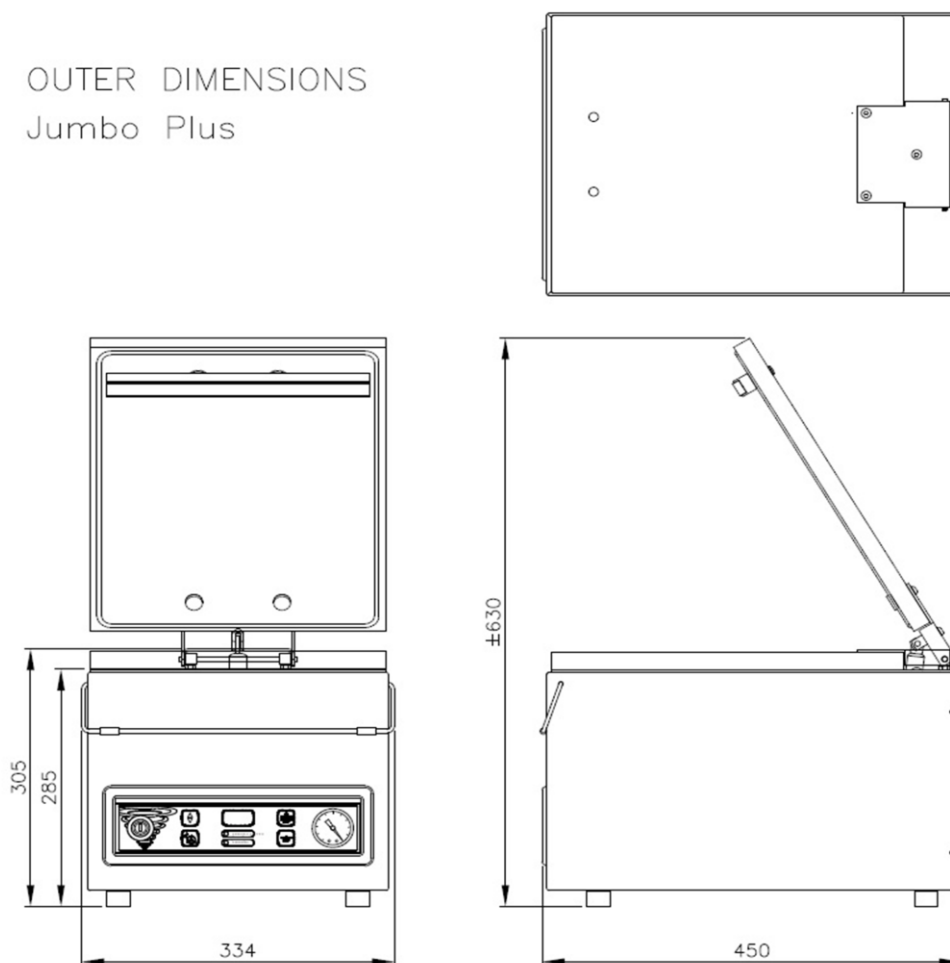

Model	Dimensions (mm)		Voltage*	Pump capacity (m <sup>3</sup> /h)	Power (kW)	Weight (kg)
	Chamber (usable space) L x W x H	Machine L x W x H				
Jumbo Plus	310 x 280 x 85	450 x 334 x 305	230V-1-50	8	0,4	32

\* Other voltages available



Diamond Europe s.a./n.v.

92 Chaussée de Vilvorde  
92 Vilvoordsesteenweg  
1120 Brussels  
Belgium

info@diamond-eu.com  
Phone: +32 2 420 26 26  
Fax: +32 2 420 67 66  
www.diamond-europe.com